



EMPC Rulebook

V3.0
11-Juni-2026

Index

- Index..... 2
- Introduction..... 3
- 1. General competition rules 3
- 2. Safety..... 3
- 3. Euro Cup / EC events 4
 - 3.1 Euro Cup / EC participation 4
 - 3.2 Event info..... 4
 - 3.2.1 Preparing for a round of competition 4
 - 3.2.2. Drivers' meeting 4
 - 3.2.3. Warming up..... 4
 - 3.3. Euro Cup / EC Competition..... 5
 - 3.3.1 Euro Cup /EC classes 6
 - 3.3.2 The Sledge 7
 - 3.3.3 Points..... 7
 - 3.3.4 The Track 8
 - 3.3.5 The competition supervisors 8
 - 3.3.6 Disqualification..... 8
 - 3.3.7 General..... 9
- 4 Technical specifications..... 10
 - 4.1 Target..... 10
 - 4.2 The execution 10
 - 4.3 General regulations 10
 - 4.4 Specific requirements..... 13
 - 4.5 The technical inspection..... 14
 - 4.6 Sledge 14
 - 4.6.1 Approved sledges:..... 14
 - 4.6.2 Sledge requirements 14
 - 4.7 Turbine Regulations..... 15
 - 4.7.1 Definitions 15
 - 4.7.2 Introduction..... 15
 - 4.7.3 Practical regulations 16
 - 4.7.4 Design 16
 - 4.7.5 Protection of the engine 16
 - 4.7.6 Fuel systems 16
 - 4.7.7 Lubrication systems..... 17
 - 4.7.8 Installation..... 18
 - 4.7.9 Safety during use..... 18
 - 4.7.10 Maintenance 19
 - 4.7.11 User's qualifications 19
 - 4.7.12 Measurements and requirements 19
 - 4.7.13 Thrust and maximum weight 20
 - 4.7.14 Turbine drawing 21
- Appendix 1..... 22
- Appendix 2..... 23
- Appendix 3..... 24

Introduction

The European Micro Pulling Committee (EMPC) introduced this rulebook as a guide for micropullers in Europe. Hopefully it will help making micropulling easy and fair as we strive to standardize rules across Europe.

Whenever more information is needed, please contact the EMPC technical representative, or your national micropulling organization. All individual inquiries from pullers, promoters, etc. must go through the respective national boards, which, if needed, will pass them on to the EMPC.

Neither the EMPC Board, nor the technical commission of the EMPC, nor any of their members can be made responsible for any damage or loss of technical or other kind, or for any kind of human injury that may be caused by the micropulling sport.

1. General competition rules

The EMPC board is allowed to change any rules regarding the Euro Cup / European Championship (further on EC) classes if needed. The competitors will be informed upfront about any changes e.g.: during the drivers meeting.

In any situation, not foreseen in the EMPC rulebook, the EMPC board decides.

2. Safety

- During the competition rounds and demonstrations fuel should be stored in a sealed container. Only during competitions participating drivers are allowed to carry at most 100 ml fuel in a non-sealed container such as a refill bottle or a syringe. The fuel should be out of reach of the audience at all times.
- The start box should be proper and safe. Including:
 - Moving parts (or parts thereof) of the start box, such as the starting wheels and serpentine belts, which are not required to start the models of the owner, should be shielded.
 - Electrical connections (battery terminals etc.) should be insulated or shielded in a way which prevents accidental short circuits.
 - Every start box should be equipped with an electric main circuit switch, which should be clearly visible and accessible.
 - Moreover, the starter should switch off automatically when the start button is not pressed. The start button should be located in a manner which prevents accidental activation (by third parties).
- Participants are not allowed to use alcohol or narcotics before or during use of their micro puller. It is not allowed to smoke while combustible substances are handled. Moreover, it is not allowed to smoke while handling the puller.
- Driving without a coupled sledge is prohibited.
- It is the technical commission's responsibility to perform safety checks.
- Participants are obliged to follow the technical commission's advice.
- The technical commission is supervised by the EMPC board.

3. Euro Cup /EC events

3.1 Euro Cup / EC participation

- All Euro Cup / EC competitors must be a member of a local micropulling organisation which is associating in the EMPC.
- All competitors should be at least 14 years old to compete in any Euro Cup / EC class, except the limited classes (Two Wheel Drive, Pro-Stock, 3,0 Modified or any other limited class). Competitors in limited classes younger than 14 years old must be assisted by an experienced member (over 14 years old).
- Guest competitors are permitted only, when their vehicles pass the technical and safety inspection. Guests compete outside the Euro Cup / EC competition. The EMPC board decides if, and what amount of guests are permitted.
- All competitor vehicles must pass the technical and safety inspection prior to participate in any Euro Cup / EC class.
- A micropuller is allowed to compete in maximum two different Euro Cup classes.
- A micropuller must have competed in the local/national championships to be able to compete during the European Championships (EC) for that year.

3.2 Event info

3.2.1 Preparing for a round of competition

Technical inspection

- Before starting and driving the micro puller(s), every participant has to offer his micro puller(s) to the technical commission for inspection. This can be done in a specific order based on puller class.
- In case of a rejection, the participant is allowed to repair his micro puller, after which it can be reassessed. The participant is obliged to follow the advice of the technical commission.
- If the micropuller participates in 2 classes, the participant is allowed to get the micro puller assessed for both classes simultaneously, provided that, according to the technical commission, this does not take too much time.

3.2.2. Drivers' meeting

- Decisions concerning the competition, made during a drivers' meeting, are conclusive, provided that all participants of the meeting unanimously approved of the decision. This means that after completion of the classes to which these decisions apply, the decision is no longer open to discussion. In case one or more members have doubts before the completion of their class, they should notify the others. Then, based on the decision made, a tentative result will be noted. Thereafter the EMPC board will decide whether the decision was correct or not.

3.2.3. Warming up

A participant may only warm up during a class he participates in. He is allowed to warm up during a break before his class or 10-15 minutes prior to the competition. It is also not allowed to warm up without a transmitter during another class.

3.3. Euro Cup / EC Competition

- The EMPC board must authorize all Euro Cup / EC events.
- Competitions are only held in officially recognised classes.
- Conditions for recognising a class in a competition:
 - At least 2 pullers manage to pull a measurable distance during a pulling attempt.
- Attempt to start / pull:

An attempt consists of an attempt to start and to pull. The attempt to start can commence as soon as the competition supervisor gives the participant the appropriate sign.
- Passing on:

The participant has 3 minutes to attempt to start. If no attempt to pull has been initiated within 2 minutes, the participant will have to make a choice:

 - Initiate an attempt to pull within the same 3 minutes; the right to pass on will expire and this attempt will be registered as an irrevocable attempt, regardless of whether or not an attempt to pull follows.
 - To pass the attempt on. In that case, the attempt to start will be ended immediately, and no irrevocable attempt will have been made.
 - Only once per round the attempt can be passed on.
 - Considerations:
 - In case of passing on, the attempt will be passed on to the last position in the starting schedule.
 - Passing on is at one's own risk.
 - No reason has to be stated for passing on.
- The participant is responsible for coupling and uncoupling the puller from the sledge.
- The attempt to pull starts as soon as the end flag controller clearly shows the green flag to the participant. From that moment the attempt is official and irrevocable.
- Uncoupling and / or manually moving the puller is not allowed after starting an attempt. Adjustments which can be made while the puller remains in position and coupled are allowed.
- If the puller does not get away during starting, the participant can request the competition supervisor to move the micro puller at most 1 time.
- The puller should start moving by itself, and should not be assisted by anyone.
- 3 meter rule.
 - If the attempt is stopped (voluntarily) within 3 meter from the starting position, the participant has the right to restart the attempt.
 - This should be done immediately and within the remaining time.
 - Restarting is allowed, passing on is not allowed.
 - The participant will never be disqualified in case of a (voluntary) stop of the attempt within 3 meter from the starting position, unless the puller has gone off the track.
 - A participant can only use the 3 meter rule once per attempt.
 - The participant should indicate, prior to uncoupling the micro puller, whether a distance below 3 meter should be measured. If he does not, the attempt and any achieved distance expires automatically, and the attempt will be disqualified.
- During the attempt the participant is obliged to follow the signs/suggestions of the competition supervisor/end flag controller.

- Flag signs:
 - Green flag:
Commence attempt to pull; the green flag is shown when the micro puller is coupled to the sledge and the participant is ready to commence the attempt to pull.
 - Red flag:
End of attempt to pull, cease attempt immediately. The red flag is shown when:
 - The end flag controller has noticed a violation.
 - The sledge has come to a standstill.
 - A Full Pull has been achieved.
- Placement in to the Pull Off is only possible through achieving a Full Pull.
 - In case of a Full Pull, the remaining attempts within the round expire.
 - After being disqualified, one retains the right for the remaining attempts within the round, unless the puller does no longer comply with the regulations.
 - During the attempt the driver may place a helper along the track.
- Besides the mentioned officials, the participant and the helper, nobody is allowed on or nearby the track, unless the competition supervisor has given permission.
- Measuring the pulled distance.
 - Upon completion of a pull, the distance from a fixed spot which, during commencement of the pull, is positioned in the middle of the track to a fixed spot on the sledge is measured.
- The pulled distance only is relevant to the end result. The winner will be known once, within a round, one or less micro pullers have pulled a Full Pull .
- Round 1 consists of at most 2 attempts, while the Pull Off consist of 1 attempt.

3.3.1 Euro Cup / EC classes

The actual classes are:

- 2,9kg Two Wheel Drive (TWD)
- 3,0kg Modified
- 3,2kg Truck
- 3,5kg Modified
- 3,5kg Super Stock
- 3,5kg Pro Stock
- 3,5kg Light Super Stock
- 4,5kg Modified
- 4,5kg Super Stock
- 5,5kg Modified

Any new initiated class must have competitors in at least two EMPC organisations, to be able to become a Euro Cup / EC class. New classes can be added only by the EMPC board.

To become an active Euro Cup / EC class for the year, it must have competitors from at least two different countries, this will be reviewed by the EMPC board per year.

3.3.2 The Sledge

- During Euro Cup / EC events, only sledges approved by EMPC members will be used.
- Only the competition supervisor has a say in how to adjust the sledge.
-
- Test pull:
 - At most 3 test pulls are used for adjusting the sledge during qualification.
 - Only in case the sledge is adjusted to a heavier setting, all previous attempts expire. If a sledge is adjusted to a lighter setting, all previous attempts are converted into test pulls (the participant can choose whether or not to redo them).
 - The first attempt which the final adjustment is made is a test pull as well, and can, depending on the preference of the participant, either be redone or made official. In case the participant decides to redo the test pull, he should notify the competition supervisor immediately after the pull. If he does not immediately notify the competition supervisor, his right to redo the pull expires.
- At all times a spare sledge should be present during competitions. The competition supervisor decides which sledge will be used.
- In case multiple participants/officials doubt the operation of the sledge, the technical commission should assess it. If the sledge is rejected, all attempts in that class will expire. The class will then be restarted. (In case the issue occurred from a clearly defined moment, only the attempts after and at the time of the occurrence expire.)

3.3.3 Points

The Euro Cup ranking is:

Place	Points
1	20
2	17
3	15
4	14
5	13
6	12
7	11
8	10
↓	10
Technical inspection only	5

- If a puller passes the technical inspection, but can't move the sledge over a measurable distance, the ranking is 5 points.
- Only the longest pulled distance is relevant to the classification.
- In case of equal distances (=equal classification) the points are equally divided over the associated pullers.
- If a micro puller has only made disqualified attempts, the points will be awarded as follows:
 - During the qualification (1st round):
 - If the sledge has been moved over a measurable distance: 5 points.
 - If the sledge has not been moved over a measurable distance: 0 points.

- During the finals:
 - If the sledge has not been moved over a measurable distance, this is equal to a disqualified (DQ) or get out of bounds (OOB). If during the Pull Off multiple pullers drive a disqualified (DQ), out of bounds (OOB), or an immeasurable distance (and as such score "equally"), then the points for these positions will be divided among these pullers.
- "Measurable distance" is defined as; a distance of at least 1 cm, measured from the bar against which the sledge was initially positioned to the point where the rear wheel touches the track.
- If the micropuller only makes disqualified pulls (but the sledge is pulled over a measurable distance), it is awarded 5 points.

3.3.4 The Track

- The track is at least 10 and at most 15 meters long and at least 1.5 and at most 2.5 meter wide. The track should have an additional length of at least 2 meter, used for slowing down the micro pullers.
- Usually, after every pulling attempt, the track is prepared, with the goal of offering every participant a track of similar quality.
- In the following cases, no track maintenance will take place:
 - The participant makes two pulling attempts consecutively.
 - The participant makes use of the "3 meter rule".
 - The participant does not want track maintenance.
 - The competition supervisor decides no track maintenance is necessary to provide a similar quality track, and the participant does not object

3.3.5 The competition supervisors

The competition supervisor is ultimately responsible for the competition and the decisions made with regards to the competition. The competition supervisor is supervised by the EMPC board. In case a participant does not agree with the decision made by the competition supervisor, he should immediately consult with the board. The board will then decide whether the decision was fair or not. Arguments between the members and the competition supervisor should be prevented. In case arguments occur or even escalate, the board will discuss this with the relevant member(s) and possible apply sanctions.

3.3.6 Disqualification

- Disqualification is decided on by the competition supervisor, in consultation with the end flag controller.
- In the following cases disqualification occurs.
 - If the micro puller has not been passed the technical inspection.
 - If relevant adjustments of the micro puller are made without permission and/or reinspected by the technical commission.
 - If the participant has used alcohol and/or narcotics prior to or during the competition.
 - If the micro puller, due to negligence, is not ready while commencing the attempt to start.
 - If the participant moves his puller after the green flag has been shown and without permission from the competition supervisor.

- If one or more wheels of the micro puller touches, crosses or clearly pushes side line of the track.
- If the micro puller gets a red flag within the 15 meter for any other reason but an end of the attempt.
- If the signs of the competition supervisor and/or end flag controller are ignored.
- If parts of the micro puller are lost, except in case of breakage
- If the micro puller is uncoupled prior to measuring.
- In case of severe negligence, which may affect the competition or cause danger.
- If the micro puller is no longer under control of the participant due to attributable failure or attributable technical/mechanical defects.
- If the micro puller has incurred damage after inspection, to the extent that it no longer complies with the regulations (broken clutch, no or poorly functioning steering wheel or gas servo, etc.), which will be decided on by the competition supervisor. In such cases the participant has the right to get his puller reinspected. In case reinspection indicates that the puller is technically ok, the remaining attempts may still be made.
- If the maximum starting time of 3 minutes is exceeded.
- If the participant himself, within 3 minutes upon commencement of the attempt to start, indicates that he does not want to make an attempt to pull, unless he or she still has the right to pass on and wishes to do so.
- If the participant does not commence his attempt from a standstill position. The wheels should not move during the commencement of the attempt to start.

3.3.7 General

- In every case which is not mentioned in the competition regulations, the bylaws, the internal regulations and the technical regulations, the competition supervisor decides.
- In case a participant does not agree with the decision made by the competition supervisor with regards to his own or someone else's attempt to pull, he should notify the competition supervisor immediately. That means at the latest before the next participant commences his attempt. Any complaints made at a later time will not be taken into account.

4 Technical specifications

4.1 Target

The EMPC competitors are all aware of the technical regulations and agree with the content and its execution

4.2 The execution

- The technical commission is responsible for the execution of the technical regulations and for ensuring their enforcement.
- The technical commission is supervised by the EMPC board

4.3 General regulations

- The micro puller may only be driven through a radio-controlled servo drive. This can be done through one of the methods described below:
 - By controlling the front wheels.
 - By braking the rear wheels separately.It is not allowed to use a controllable hitch.
- The steering system should actually function during an attempt.
- Only the rear wheel drive vehicles are allowed.
- A roll bar (or cage) is compulsory (except in the Two Wheel drive class); this serves as a handle for the micro puller.
- The power source should be 1 or more engines. The number to be used depends on the class in which the micro puller participates.
- Exhaust pipes are compulsory and may not cross the **centre** of the rear axle. An exception applies to the Two Wheel Drive class, where the exhaust pipe may cross the **centre** of the rear axle, provided that it is situated below the body.
- The micropuller should commence its attempt from a standstill position.
- Requirements concerning the construction of clutches and clutch bells (all sizes of clutch bells should be measured without any clutch linings).
- General:
 - The largest diameter of a clutch (excluding the clutch bell, including any friction lining) may never exceed 100 mm.
 - Concerning Super-Stock pullers: the clutch bell should be built within the hood.
 - The clutch bell should consist of one part, with the exception of any friction lining
 - Clutch bells may only consist of steel or aluminium
 - If the clutch itself has been equipped with friction material and an aluminium clutch bell is used, a steel inner ring with a minimum thickness of 1 mm is no longer compulsory! However, in that case the clutch bell should have a thickness of 1 mm. The minimum thickness of the aluminium part remains the same.
 - Every clutch should be equipped with a clutch protector, which prevents the clutch bell from moving backwards. The protector should be properly fixed to the puller, preferable fixed to the engine. It is not allowed to fix the protector to a moving part of the power train or a weak part, such as the hood / body.
- Every on the market available centrifugal clutch may be used, provided that it complies with one of the conditions below:

- The supplier should offer the combination of the engine and parts as a package.
- The clutch is used in combination with the (steel or aluminium) clutch bell, engine and exhaust pipe for which it was originally intended. The combination of the engine and exhaust pipe may not be adjusted in order to increase the highest available capacity and / or the number of revolutions.
- The clutch is used in combination with the (steel or aluminium) clutch bell for which it is intended and the highest number of revolutions achieved by the clutch is never higher than what the clutch is intended for. This should be sufficiently supported by the participant.
- The clutch is used in combination with a clutch bell which complies with the regulations concerning self-made clutch bells (see attachment 3).

Requirements with regards to self-made Centax, Crower and centrifugal clutches in accordance with the Vario principle:

- Centax clutches:
 - All Centax clutches need to be equipped with a starting disk with a collar, which should extend at least 3 mm beyond the opening between the starting disk and the clutch house. The wall thickness of the clutch house can be taken from the existing table in the technical regulations, with a maximum of 3mm.
- Crower clutches:
 - The bolts which fix the plates together should at least have a quality of 8.8.
 - The driver should, before driving an EMPC event, present the opened clutch to the technical commission, in order for them to weigh the fingers and pins. The wall thickness of the shielding to be used will be based on their weight. This should cover the entire clutch from the starting disk until 5 mm beyond the fingers and around the exiting axle.
 - For every clutch, the TC calculates the force which may be exerted by the fingers and the pins. Based on that calculation, the minimal wall thickness of the shielding will be selected.
- Vario clutches:
 - Self-made Vario clutches may only be used in combination with a clutch bell which complies with the regulations concerning self-made clutch bells (see attachment 3).
- Other self-made clutches:
 - Participants who would like to use self-made clutches which do not work according to the Vario, Crower or Centax principles, should first provide the technical commission with a drawing with specifications (materials to be used, range of applicable number of revolutions, etc.) of their clutch. The technical commission will consult the management whether such a construction may be used or not.

Requirements with regards to the hitch:

- The hitch should be readily accessible and enable quick coupling and uncoupling.
 - Measurements:
 - Minimal length: 4.5 cm, measured from the centre of the rear wheel until the centre of the drawbar eye.
 - Minimal diameter drawbar eye: 10 mm.
 - Minimal thickness:
 - In case of an aluminium or steel plate: 3 mm.
 - In case of a steel eye: 5 mm diameter.
 - Attachment: at least one steel bolt \varnothing 5 mm or 2 steel bolts \varnothing 3 mm, fixed thoroughly to the frame of the rear axle and secured with locknuts.
- Use of a differential is compulsory.

Requirements concerning rear tyres:

- When selecting the maximum measurements one should assume an uncut tyre, without a rim, foam inserts, etc.
- The only permitted tyre profile for the rear tyres is the so-called V-tread profile, which means that the tyre has V-shaped combs.
- Mudguards above the rear wheels are compulsory.
- Gears should be completely shielded with an aluminium, carbon, steel or polycarbonate strip. The thickness of the strip should be at least 1.5 mm and should extend 1 mm on both sides of the gears. This shielding should be properly fixed to the frame with at least 2 M3 bolts. The construction and execution will be inspected by the technical commission. A closed gear box (cross box) is preferred.
- Attributable transmitter failure as a result of improper wiring and/or attachment of servos and receivers will result in disqualification.

4.4 Specific requirements

	Modified (limited)	Modified	Super Stock	Light Super Stock	Pro Stock	Two Wheel Drive	Trucks
Weight [kg]	3.0	3.5 4.5 5.5	3.5 4.5	3.5	3.5	2.9	3.2
Length from centre rear wheel [mm]	426	426	400	400	400	400	440
Width [mm]	320	320	320	320	320	260	260
Height [mm]	300	300	300	300	300	Free, limited by body	Free, limited by body
Distance extending the centre: Rear wheel [mm] Front wheel [mm]	130	130	80 50	80 50	80 50	80	80
Hitch height [mm]	55	55	55	55	55	76	76
Min. hitch length from centre rear wheel to centre hitch hole [mm]	45	45	45	45	45	45	45
Rear tire dimensions (diameter*width) [mm]	175 * 110	175 * 110	175 * 110	175 * 110	175 * 110	115 * 70	115*70
Number of engines	1 (1 cylinder)	Free	1	1 (1 cylinder)	1 (1 cylinder)	1	1
Electric engine limitations	Max. 2 engines with 3.2mm axle diameter. Max battery driving voltage 9.6V Max 1 mechanical or 2 electrical drive controllers Brushless engines are not allowed	No limit	Not allowed	Not allowed	Max. 1 engine -With brushes max 5mm axle diameter. Max battery driving voltage 11,1V -Brushless max 5mm axle diameter and 2200 Watt. - 1 battery with: 2 cells LiPo 7.6V 8 cells NiMH/NiCd With max 9.6V driving voltage	Not allowed	Not allowed
Engine displacement limitations [cc]	2-stroke: 3.5 4-stroke: 10.0 4-stroke + charger: 8.56	No limit	No limit	2-stroke: 10.0 Standard airplane engine with front carburettor* Not allowed: -Marine race engines (such as CMB and OPS) -Car or buggy engines -Ducted fan engines (OS 61 VR-DF)	2-stroke: 2.5 1:10 car engine	10,0	2-stroke 10 cc 4-stroke 20cc without charger
Location and position of exhaust	Free	Free	Under the hood, outflow upwards	Under the hood, outflow upwards	Under the hood, outflow upwards	Under the body, outflow free	Free
Location of battery packs and servo's	Free	Free	As much as possible under the hood	As much as possible under the hood	As much as possible under the hood	Free	Free
Hood or body	Free	Free	Any type of hood is required	Any type of hood is required	Any type of hood is required	Any type of body is required	Any type of body is required
Dimensions hood or body Length [mm] Width [mm] height (excl. Steering wheel, measured from ground)	Free	Free	360 100 250	360 100 250	360 100 250	Scale 1: 10	Scale 1:14 Scale 1:16
Wheelbase (mm)	Free	Free	2900	2900	2900	Free	Free

Unless otherwise specified, the given values are the maximum values.

*If not clearly identifiable, the user should be able to show the origin of the engine during the technical inspection.

4.5 The technical inspection

- Technical inspection of the pullers takes place in accordance with regulations as described in the competition regulations. The technical commission retains the right to run sampling tests.
- Technical inspection of a micropuller takes place when the puller is ready to start.
- The weight of the micro pullers will be measured when the puller is ready to start; this means with filled fuel tanks and the tyre pressure which will be used during the competition.

4.6 Sledge

The EMPC technical commission decides about the EMPC sledge approvals. Any sledge will be inspected by the EMPC technical commission, before EMPC approval will be given.

4.6.1 Approved sledges:

Any sledge can be registered when they are proven during Currently sledges approved by the EMPC.

The Netherlands :

- The Judge (NMPO)
- Keep moving orange (NMPO)

Germany :

- Mr. Heavy (RCTP)
- Broken Dream (RCTP)
- Little Shadow (RCTP)
- ~~Green Shadow (RCTP)~~

4.6.2 Sledge requirements

All EMPC approved sledges should comply with below mentioned requirements:

- The sledge will, prior to the competition, be inspected by the technical commission.
- The sledge may, in accordance with the competition regulations (and only in those specific cases), be inspected once more.
- The sledge must be equipped with a specified point to measure the distance.
- The chain connection point on the sledge should stay 8–10 mm above the track, to prevent wear. (see appendix 1)
- The total chain length must be 100-105mm, measured from the inner side of the first chain link and the inner side of the hook. (see appendix 1)
- There aren't any special requirements for the sledge; however the brake function should comply with the currently approved sledges.
- Any new sledge should have been proven during at least 3 national events, before an EMPC approval will be possible.

4.7 Turbine Regulations

These guidelines are compiled by the Technical Commission (TC) and published to stimulate the construction and safe use of turbines. The content of the guidelines originates from the combined knowledge of people who have gained significant experience with building and using turbines.

Although it has been our primary concern to prevent mistakes and omissions, the writers cannot be held responsible for any issues caused by following these guidelines. Safe use of every turbine remains the responsibility of the user.

4.7.1 Definitions

People who follow the guidelines should understand that throughout the guidelines wordings with specific meanings are used, as described below:

Must - indicates an absolute obligation to follow the requirement. There are no circumstances under which this requirement would be eased.

Should - indicates an obligation to follow the requirement for as much as this is practically achievable. The requirement could be eased, but only under exceptional circumstances. One should have a very good reason, not to comply with the requirement.

Could/can - indicates a preferential method, based on general experience. Not complying with this rule is not expected to cause any dangerous situations.

4.7.2 Introduction

Those who plan to build a turbine for use within the EMPC should first study these general safety requirements. These are specific topics concerning the safety of turbines. In particular the following risks are relevant:

- Danger of burns or damage resulting from exhaust fumes;
- Fire danger after a crash, ignited by hot parts. This danger is more prominent due to the relatively high volume of fuel which is usually carried;
- Danger of overheating due to an incorrect starting procedure or a damaged engine;
- Fire or explosion danger due to incorrect handling of liquid propane gas or similar fuels;
- Risk of injuries as a result of parts which, in case of breakage, leave the engine at a high speed.

After a crash, the turbine must in all cases be disassembled for inspection.

There are seven approaches which prevent the risks mentioned above:

1. Ensure that users have a high level of skills, knowledge and experience, for them to avoid dangerous situations;
2. Ensure that damages to engines and incidences occur as little as possible by assessing reliability and through meticulous, methodical design procedures, operational procedures and maintenance;
3. Ensure fail-safe constructions and, where necessary, emergency stop devices, to make sure that incidences cause minimal risks;
4. The engines should run at a moderate maximum power output. This leaves sufficient leeway in case the engine overruns or overheats;
5. Design the outer jacket of the engine in such a way that, in case of breakage, the parts are retained within the jacket;
6. Only coupled micro pullers may be started;
7. Before taking part in a competition or demonstration with a puller with turbine actuation, the member must prove that he is in full control of his micro puller. This should be done in the presence of the TC.

An entirely safe approach takes all seven points into account.

4.7.3 Practical regulations

4.7.4 Design

- All engines, irrespective of their design, must be extensively tested prior to public use. The aim is to determine a 'life cycle', to assess whether all parts can resist the stress of the running engine.
- All materials must be suitable for the application they are used for.
- In case of a published design or a commercially built engine, no inferior materials should be used. Also parts which are under great stress should not be adjusted.

4.7.5 Protection of the engine

- Engines under development must be tested extensively, and during such tests exceeding the design parameters of the engine must be prevented (especially concerning the number of revolutions and temperature).
- Through fail-safe methods, the maximum fuel supply must be limited in order to prevent the engine to run at a higher number of revolutions and temperature.
- Protection against a too low number of revolutions should be integrated into the regulation of the engine.
- Safety systems of the engine should ensure that the engine returns to the 'safe' area in which the engine can run. The engine should only turn off when all other options have been exhausted.

4.7.6 Fuel systems

- The fuel tanks must be shielded from the heat of the engine.

- In order to minimise the chances of cracking or breakage during a crash, the fuel tanks and components of the fuel system must be properly fixed and protected.
- A mechanical switch must be fixed inside the fuel supply line from the tank, and there must be a switch to turn off the power supply to the electrical fuel pump. This switch must have, besides possibly a servo control, a manual control, which must be easily accessible.
- The fuel system should have an in-built restriction, which limits the maximum amount of fuel supplied by the fuel pump to what is needed for running the engine at the maximum number of revolutions.
- In case a remote control is used, a fail-safe system should automatically turn off the fuel supply when radio contact is lost. The system should prevent the fuel supply from opening automatically when the radio contact recovers. In order to prevent unnecessary measures, the fail-safe system may have an in-built delay to prevent it from acting during short interruptions of the radio contact. This delay should however not be too long, which would undermine the advantages of the fail-safe system.
- Fuel supply lines, clutches and associated devices must be tested to ensure that they can handle the pressure. The parts may not leak or break while the engine runs on the highest safe number of revolutions. Where, due to leakage, fuel can collect, drainage holes must be put in place.
- The supply of gas during starting and the supply of liquid fuel must be done through different fuel supply lines, in order to prevent gas from entering the liquid fuel tank.
- The liquid fuel tanks should never be exposed to high pressure. In specific systems a low pressure is allowed (max. 0.35 bars) to facilitate the flow of fuel between the tanks and the fuel pump.
- Tanks for gaseous fuels are prohibited.
- All fuel tanks and fuel supply lines should be regularly checked for ageing and wearing. Parts should, if necessary, be replaced, in which cases special attention should be given to hardening of flexible hoses and closures on clutches which are under high pressure.
- In order to prevent contamination of the fuel system, only clean, filtered fuel should be used.

4.7.7 Lubrication systems

- The oil reservoir should be positioned in a location which facilitates quick and easy checking of the oil level.
- The lubrication system must be designed, or the user must take measures, to prevent oil from entering the engine as a result of siphoning (siphon-trap) or thermal expansion.
- The oil reservoir should be located nearby the engine, or the oil supply line to the engine should be primed. (To minimise the delay of supplying oil to the engine.)
- The oil flow must be regulated to supply the right amount of oil, as specified by the designer or manufacturer.
- Oil, suitable for use in turbines, must be used.
- The oil supply lines and associated devices must be made from materials which are suitable for the intended application, and which are suitable for the circumstances they are exposed to (aggressive liquids, heat).
- Oil supply lines and associated devices must be able to resist the highest occurring pressure of the lubrication system without leakage or breakage.
- It should be possible to assess whether oil flows to the engine once the engine has been started.

4.7.8 Installation

- Engines must be fixed securely in a way which ensures that they remain in position under all circumstances.
- All parts located nearby the engine must be fixed securely, to prevent them from being sucked inside by the engine.
- The engine must be shielded from external objects through use of suitable shielding or by choosing a suitable position of the air-intake.
- Pipes, lines, wires etc. should be kept away from the hot parts of the engine, or should be suitable for the occurring temperatures.

4.7.9 Safety during use

Fire

- An effective, working CO2 fire extinguisher (or another suitable extinguishing agent) and someone knowledgeable and experienced in handling it, must be available every time the engine runs.
- Turbines may not run in areas with fire danger, unless sufficient preventative measures have been taken to exclude such risks.
- Smoking and other sources of ignition are prohibited within a range of 10 meters during decanting, releasing or tanking inflammable gases.
- All fuels must be stored in the shade in suitable containers or tanks, on which the contents are clearly indicated.
- Engine fires are a danger, and people should be entirely conscious about possible causes. These include:
 - Remaining fuel in the engine, causing a 'wet start'.
 - Wrong starting procedure.
 - Scraping of the turbine.
 - Redundant lubrication oil being pressed into the engine during priming of the lubrication system.
 - Remaining materials, partly blocking the intake and reducing the performance of the compressor.
 - Blocked fuel injection.
 - Expansion of fuel inside the engine after switching off the fuel pump.

Test run

- In preparation of and during running of the engine a checklist procedure should be followed.
- The first test runs of a prototype engine should not be executed in a publicly accessible place. Only people essential for running the engine and safety personnel should attend.
- The testing space must be properly ventilated.
- Any mechanical deviations caused by vibrations, excessive noise, heat, number of revolutions or any other unexpected issues must be inspected and adjusted prior to restarting the engine.

Use in public space

- An engine can only be used in public if the user entirely understands how the engine operates.

User instructions

- One must always follow the manufacturer's or the designer's user instructions.

4.7.10 Maintenance

- Engines require regular maintenance. The regularity and thoroughness of the inspections and other maintenance depends on the engine installation. The maintenance ranges from external inspections before every pull to complete dis-assembly of the engine at regular intervals.

At least the following inspections must take place at regular intervals, preferably before every pull.

- Before every starting procedure, a visual inspection for leakages of the fuel and oil systems.
- A visual inspection of the compressor and the turbine blades for signs of damage. A small damage to the compressor blade, visible from the intake, may indicate a large damage due to external objects inside the engine; this must be looked into before restarting the engine.
- A visual inspection of the filters (if accessible and applicable), to ensure there are no contaminations.
- Inspecting the fuel and oil systems for blockages.
- Checking the installation of the engine and other systems on deterioration, damaging or looseness.

At the request of the TC, a participant may have to keep a logbook for every engine, in which the following should be included:

- The date on which the engine has run.
- The duration the engine has run.
- The total running time of the engine until that date.
- Data concerning all executed service, maintenance and repairs, including the replaced parts. Moreover, all replaced parts should be presented to the TC for inspection, during which the reasons for re-placement should be explained.
- All other details which may be relevant for establishing a 'life cycle' and determining maintenance intervals.

4.7.11 User's qualifications

- Inexperienced users must, where possible, request for assistance from experienced users when running a turbine. In case of doubt - request help from third parties.
- In order to let the user gain experience in starting and running the turbine, the first runs of the engine must take place in a testing environment. Until such experience has been gained, the user may not run the engine in public.

4.7.12 Measurements and requirements

- Single-axle turbines may only be used if they are commercially available and specifically manufactured to actuate a mechanism. Self-made turbines may only be used if they are of the dual-axle type (so-called free-power turbines).
- The speed regulation of the fuel pump must be equipped with a so-called fail-safe. Preferably the engine should be equipped with an electronic control unit (E.C.U.).
- Three types of fuels are permitted; kerosene, diesel and petrol.
- The intake of the turbine must be shielded with a metal mesh (steel or stainless steel) with a mesh size of at most 3 mm. The mesh should be mounted with bolts (at least 3 x M3, quality at least 8.8), a clasp around the intake chalice, or a hinge (material: steel, brass or stainless steel). The last two must be mounted in such a way, that it is impossible to pull the mesh from the chalice.
- The compressor part must be shielded by a stainless steel ring with a width of 120% of the thickness of the compressor wheel and a thickness of at least 1 mm. The ring must be mounted around the compressor part with at least 2 steel bolts (at least M4, quality at least 8.8, see drawing).

- The rear side of the turbine must be shielded by a stainless steel ring with a thickness of at least 1.5 mm, and must extend at least 10 mm in front of the first turbine wheel and at least 15 mm behind the free power wheel. This ring must be mounted with at least 3 steel bolts (at least M3, quality at least 8.8, see drawing).
- The exhaust pipe must be at least 15 mm above the turbine wheel (see drawing).

4.7.13 Thrust and maximum weight

- The total weight of a turbine puller, and as a result the weight class in which one can participate, is determined by multiplying the weight of the puller with the thrust delivered by the turbine at maximum output. This thrust must be demonstrated in the presence of the TC and can always be reassessed by the TC. Providing misinformation about this can lead to disqualification.

4.7.14 Turbine drawing

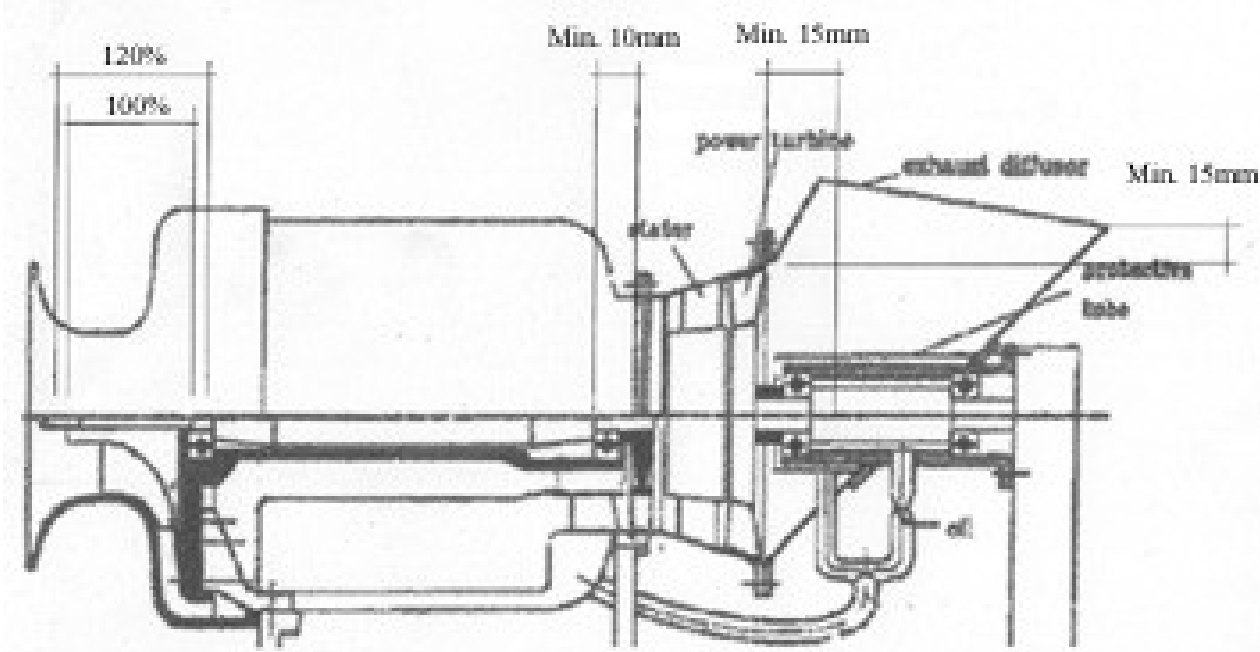

Appendix 1

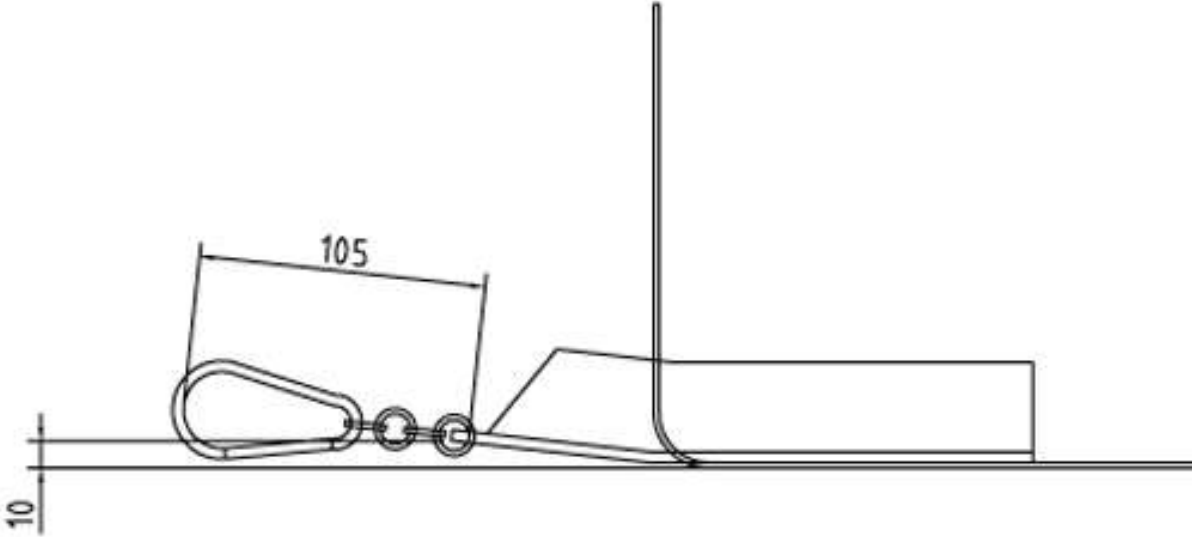

Appendix 2

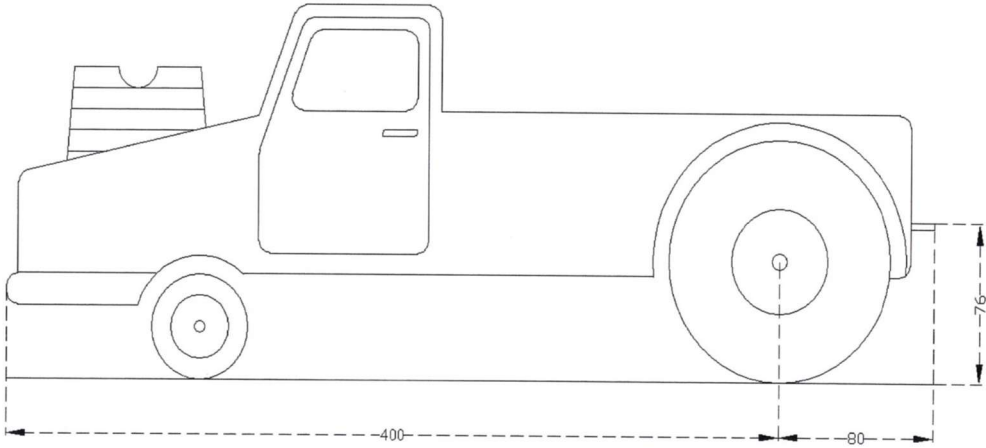
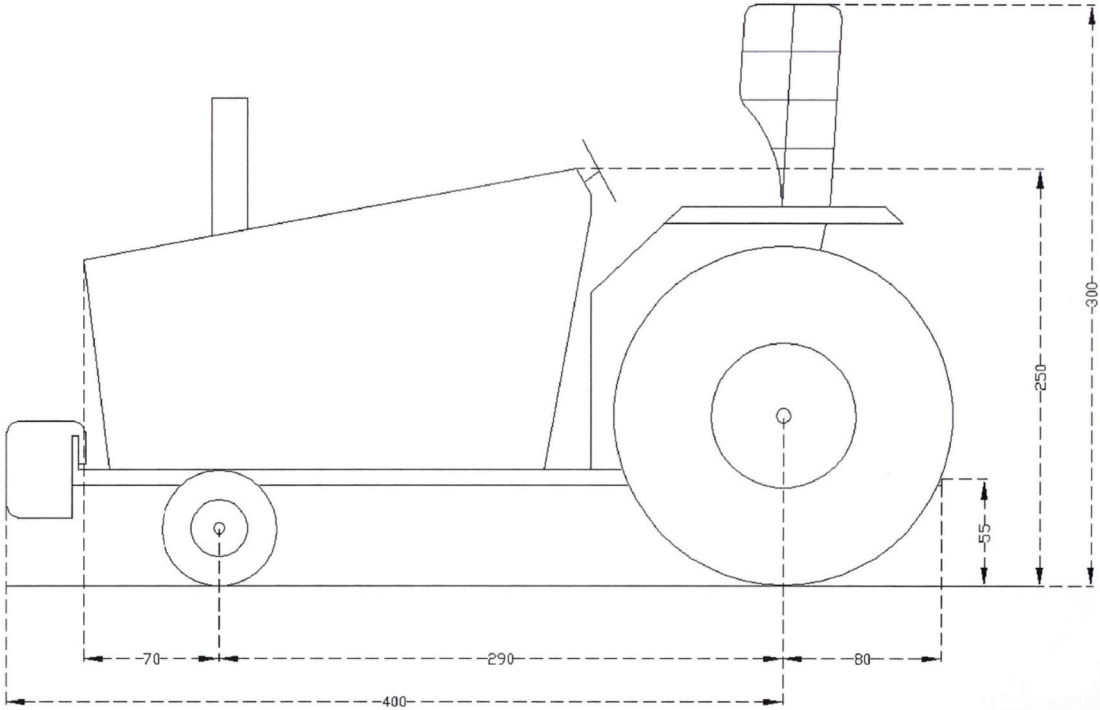
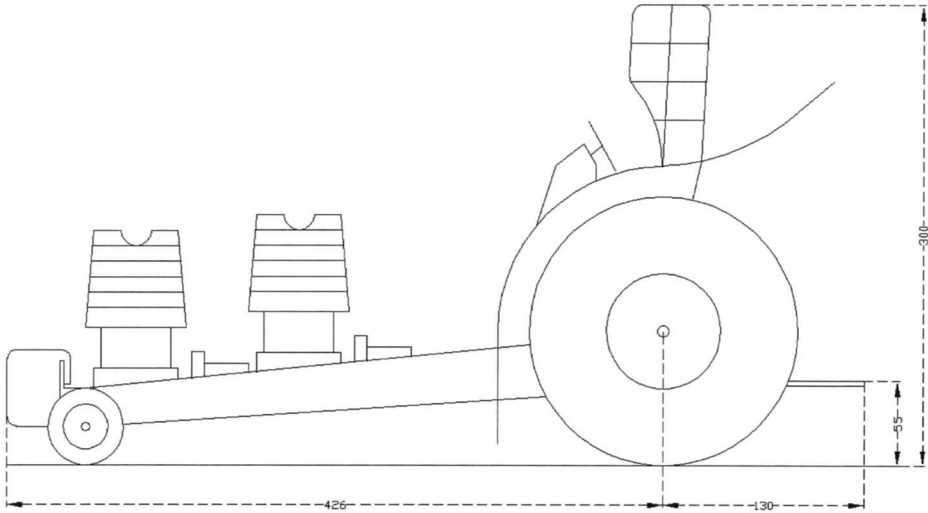

Appendix 3

Clutches should comply to either below mentioned table or:

Clutchbells without steel ring:

Minimum 3,5mm wall thickness for aluminium or minimum 1,25mm for steel.

Clutchbells with steel ring

Minimum 2mm aluminium + 1mm steel wall thickness

OR

Veiligheidsfactor s:	4	Ondergrens aluminium:	2,00
Dichtheid koppeling (staal) ρ :	kg/m ³	Bovengrens aluminium:	10,00
Treksterkte aluminium $\sigma_{t, \text{alum.}}$:	N/mm ²	Ondergrens staal:	1,50
Treksterkte staal $\sigma_{t, \text{staal.}}$:	N/mm ²	Bovengrens staal:	7,61

		Toerental koppeling ($n \leq \dots \text{ min}^{-1}$)												
		10000	12500	15000	17500	20000	22500	25000	27500	30000	32500	35000	37500	40000
Diameter koppeling ($\varnothing \leq \dots \text{ mm}$)	25	0,1	0,2	0,3	0,4	0,5	0,6	0,8	0,9	1,1	1,3	1,5	1,7	2,0
	30	0,2	0,3	0,5	0,7	0,9	1,1	1,3	1,6	1,9	2,3	2,6	3,0	3,4
	35	0,3	0,5	0,8	1,0	1,4	1,7	2,1	2,6	3,1	3,6	4,2	4,8	5,5
	40	0,5	0,8	1,1	1,6	2,0	2,6	3,2	3,8	4,6	5,4	6,2	7,2	-
	45	0,7	1,1	1,6	2,2	2,9	3,7	4,5	5,5	6,5	7,6	-	-	-
	50	1,0	1,6	2,2	3,0	4,0	5,0	6,2	7,5	-	-	-	-	-
	55	1,3	2,1	3,0	4,0	5,3	6,7	-	-	-	-	-	-	-
	60	1,7	2,7	3,9	5,3	6,9	-	-	-	-	-	-	-	-
	65	2,2	3,4	4,9	6,7	-	-	-	-	-	-	-	-	-
	70	2,7	4,3	6,1	-	-	-	-	-	-	-	-	-	-
	75	3,4	5,2	7,5	-	-	-	-	-	-	-	-	-	-
	80	4,1	6,4	-	-	-	-	-	-	-	-	-	-	-
	85	4,9	7,6	-	-	-	-	-	-	-	-	-	-	-
90	5,8	-	-	-	-	-	-	-	-	-	-	-	-	
95	6,8	-	-	-	-	-	-	-	-	-	-	-	-	
100	7,9	-	-	-	-	-	-	-	-	-	-	-	-	

Tabel 1. Minimale wanddiktes (in mm) voor aluminium koppelingsklokken.

		Toerental koppeling ($n \leq \dots \text{ min}^{-1}$)												
		10000	12500	15000	17500	20000	22500	25000	27500	30000	32500	35000	37500	40000,0
Diameter koppeling ($\varnothing \leq \dots \text{ mm}$)	25	0,1	0,1	0,2	0,3	0,4	0,5	0,6	0,7	0,8	1,0	1,2	1,3	1,5
	30	0,2	0,3	0,4	0,5	0,7	0,8	1,0	1,2	1,5	1,7	2,0	2,3	2,6
	35	0,3	0,4	0,6	0,8	1,0	1,3	1,6	2,0	2,3	2,7	3,2	3,6	4,1
	40	0,4	0,6	0,9	1,2	1,5	2,0	2,4	2,9	3,5	4,1	4,7	5,4	-
	45	0,6	0,9	1,2	1,7	2,2	2,8	3,4	4,2	5,0	5,8	-	-	-
	50	0,8	1,2	1,7	2,3	3,0	3,8	4,7	5,7	-	-	-	-	-
	55	1,0	1,6	2,3	3,1	4,0	5,1	-	-	-	-	-	-	-
	60	1,3	2,0	2,9	4,0	5,2	-	-	-	-	-	-	-	-
	65	1,7	2,6	3,7	5,1	-	-	-	-	-	-	-	-	-
	70	2,1	3,2	4,7	-	-	-	-	-	-	-	-	-	-
	75	2,5	4,0	5,7	-	-	-	-	-	-	-	-	-	-
	80	3,1	4,8	-	-	-	-	-	-	-	-	-	-	-
	85	3,7	5,8	-	-	-	-	-	-	-	-	-	-	-
90	4,4	-	-	-	-	-	-	-	-	-	-	-	-	
95	5,2	-	-	-	-	-	-	-	-	-	-	-	-	
100	6,0	-	-	-	-	-	-	-	-	-	-	-	-	

Tabel 2. Minimale wanddiktes (in mm) voor stalen koppelingsklokken.